

---

User Manual

# LDM 41/42 E

Firmware Version 7.03 and 8.03

Version 1.2

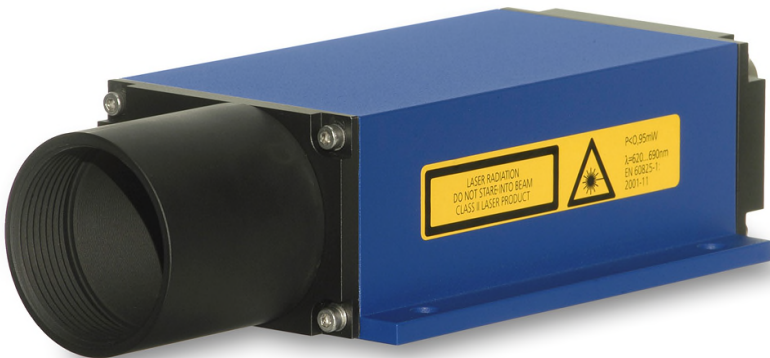

CE

---

Dear User,

You are advised to carefully read this User Manual before powering on the LDM 41/42 E Laser distance measuring sensor for the first time.

This is necessary to ensure that you will be able to utilize all the capabilities and features which your new acquisition provides.

This technology is subject to continuously ongoing development.

Editorial deadline: November 2011

Manual version: V 1.2

Firmware version:  $\geq 7.03$  and 8.03

Note:

Proper care has been used in compiling this document. No liability will be accepted in the event of damage resulting from failure to comply with the information contained herein.

**Content**

<b>1. General.....</b>	<b>5</b>
<b>2. Safety Instructions .....</b>	<b>7</b>
2.1. General Safety Instructions .....	7
2.2. Intended & Conforming Use .....	7
2.3. Nonconforming Use.....	7
2.4. Laser Classification .....	8
2.5. Electric Supply .....	9
2.6. Important Operating Advice .....	9
<b>3. Technical Data.....</b>	<b>10</b>
<b>4. Mechanical Mounting Conditions .....</b>	<b>12</b>
<b>5. Electrical Connection .....</b>	<b>14</b>
5.1. Rear-Side Cover Terminals .....	14
5.2. Assignment of Terminals .....	15
Power Supply .....	15
Fast Ethernet .....	15
RS 232 Serial Interface .....	16
Shields and Grounding.....	17
<b>6. Limiting Values for Voltages.....</b>	<b>18</b>
<b>7. Start up .....</b>	<b>19</b>
7.1. Start up with RS 232 .....	19
7.2. Start up with Ethernet.....	20
<b>8. Commands and Parameter .....</b>	<b>23</b>
8.1. General .....	23
8.2. DT.....distance tracking.....	27
8.3. DS.....distance tracking (< 7 m).....	27
8.4. DW.....distance tracking with target board (10Hz) .....	27
8.5. DX.....distance tracking with target board (50Hz) .....	28
8.6. DF.....distance measurement with external trigger ....	28
8.7. DM.....distance measurement.....	29
8.8. TP.....internal temperature [°C] .....	29
8.9. SA.....display/set average value [1..20] .....	29
8.10. SD.....display/set display format [d/h/s] .....	30
8.11. ST.....display/set measure time [0..25].....	31
8.12. SF.....display/set scale factor .....	32

8.13.	SE.....display/set error mode [0/1/2].....	33
8.14.	AC.....display/set ALARM center.....	33
8.15.	AH.....display/set ALARM hysteresis.....	33
8.16.	AW.....display/set ALARM width .....	34
8.17.	HO.....display/set temperature for heating on.....	34
8.18.	HF.....display/set temperature for heating off.....	34
8.19.	RMx y z.....display/set remove measurement.....	35
8.20.	TDx y.....display/set trigger delay and trigger level .....	36
8.21.	TMx y.....display/set trigger mode trigger level .....	37
8.22.	BR.....display/set baud rate [2400..38400] .....	39
8.23.	AS....display/set auto start command.....	39
8.24.	OF.....display/set distance offset.....	39
8.25.	SO.....set current distance to offset.....	39
8.26.	LO.....Laser on .....	39
8.27.	LF.....Laser off.....	39
8.28.	PA.....display settings.....	40
8.29.	PR.....reset settings.....	40
<b>9.</b>	<b>In- and Outputs.....</b>	<b>41</b>
9.1.	Ethernet .....	41
9.2.	Serial Interface RS232 .....	42
9.3.	Output Format Ethernet and RS232 .....	43
9.4.	Digital Switching Output (Alarm) .....	44
9.5.	Trigger Input.....	46
<b>10.</b>	<b>List of Commands .....</b>	<b>47</b>
<b>11.</b>	<b>Error Codes .....</b>	<b>49</b>
<b>12.</b>	<b>EC Declaration of Conformity .....</b>	<b>50</b>
<b>13.</b>	<b>Part Numbers.....</b>	<b>51</b>

## 1. General

The LDM 41/42 E is a Laser sensor to measure distances from 0.1 m to more than 100 m with pinpoint accuracy.

A given target can be clearly identified with the help of a red Laser sighting point. In terms of operating reach, the LDM 41/42 E performs depending on the reflectance, morphology and qualities of the target to be measured.

The sensor works based on comparative phase measurement. It emits modulated Laser light which is diffusely reflected back from the target with a certain shift in phase to be compared with a reference signal. From the amount of phase shift, a required distance can then be determined with millimetre accuracy.

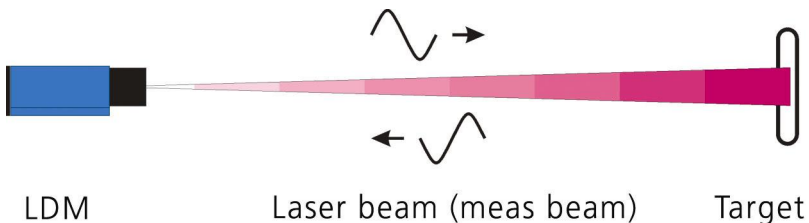

*Figure 1: Measurement principle*

A distance measuring cycle can be triggered in three different ways:

- By sending a command from the PC or another equivalent control unit by using a Telnet-client via TCP/IP (port 23) or without a Telnet connection via the RS 232
- By making appropriate prior parameter settings for the auto start command and applying supply voltage
- By external triggering (in remote-trigger mode).

For a more detailed description of these three trigger options, you should consult section chapter 8 of this User Manual.

### Special performance features are:

- Provides high accuracy and great reach under extreme outdoor temperatures.
- Works in a wide range of operating voltages from 10 V= to 30 V= from an on-board vehicle supply point, an industrial direct voltage supply net or a DC power pack.
- Features consistently low power consumption of  $<1.5 W^1$  (without  $I_{Alarm}$ )
- Up to 30 m reach for distance measurement, with potential for more than 100 m reach if additional reflectors<sup>2</sup> are mounted onto the target (depending on reflectance and environmental conditions).
- Visible Laser beam for easier sighting.
- Fast Ethernet port for input of measuring functions and commands from, and output of measured values to a PC or a PLC (Telnet connection).
- Switching output with adjustable limit and hysteresis.
- Measured values can be displayed in meters, decimetres, centimetres, feet and inches due to.
- Option for remote triggering of a measurement from an external trigger device.<sup>3</sup>

---

<sup>1</sup> inactive internal heating for devices with internal heating (LDM 41/42 E /h)

<sup>2</sup> e.g. 3M, self adhesive foil white non glossy or foil 3290 for longer distances

<sup>3</sup> Trigger function is not available for devices with internal heating (LDM 41/42 E /h)

## 2. Safety Instructions

### 2.1. General Safety Instructions

These safety and operating instructions should be carefully read and followed during practical work with the LDM 41/42 E.



There is danger of Laser radiation or electrical shock. For necessary repair work, the LDM 41/42 E may not be opened by anyone other than Manufacturer personnel. Unauthorized intervention into the inner product space will void any warranty claims.

Compliance with all specified operating conditions is necessary. Failure to observe advisory notes or nonconforming product usage may cause physical injury to the user or material damage to the LDM 41/42 E.

Cable connectors must not be plugged or unplugged under voltage. Remember to turn voltage supply off before you begin working on cable connections.

### 2.2. Intended & Conforming Use

- Measurement of distances,
- Special measuring functions,
- Compliance with prescribed temperatures for operation/storage,
- Operation at correct voltage level,
- Application of specified signal levels to the appropriate data lines.

### 2.3. Nonconforming Use

- Do not operate the LDM 41/42 E in any other way than described under "Intended & Conforming Use" above and only in a proper working condition.
- Safety devices must not be defeated or otherwise rendered ineffective.
- Information and warning signs must not be removed.
- Repair work on the LDM 41/42 E must not be carried out by anyone other than authorized personnel.
- Refrain from using the LDM 41/42 E without certified protection in an explosive environment.

- Measurement with the LDM 41/42 E pointed at the sun or other strong light sources may produce faulty results.
- Measurement of targets with poor surface reflectance in a strongly reflecting environment may also result faulty measurements.
- Measurement of strongly reflecting surfaces may deliver faulty results.
- Measurement performed through transparent optical media, for example, glass, optical filters, Plexiglas, etc. may equally produce incorrect results.
- Measurement on translucent objects (materials allow light to pass through, but are not transparency, e.g. polystyrene, wax, different plastics etc.) can give a too large measured value, since also light is reflected by deeper layers.
- Rapidly changing measuring conditions are likely to falsify the result of measurement.

### 2.4. Laser Classification

The LDM 41/42 E is a Class 2 laser product  $\leq 1$  mW as stipulated in EN60825-1:2007, Class 2.

#### Caution:

**There is Class 2 Laser radiation. Do not stare into beam!**



Figure 2: Warning Sign Laser Radiation Class 2

The Laser power is limited to maximum 1 mW. The Laser radiation is visible. A short-term exposure (duration up to 0.25 s) is harmless to the eye.

Users are instructed by Laser warning sign (see Figure 2) to do not stare into the beam. They have to protect themselves by turn the head and/or closing the eyes and by avoid a long look into the beam.

Do not direct the Laser beam onto persons.

**The sensor can use without any additional safety protection.**

## **2.5. Electric Supply**

Use only 10 V to 30 V DC (direct voltage) for LDM 41/42 E operation. Use only the specially designated connector terminal for voltage supply. Specified signal levels must not be exceeded, in order to guarantee correct data communication.

## **2.6. Important Operating Advice**

To make full use of the system's inherent performance capabilities and achieve a long service life, you should always follow these operating rules:

- Do not turn the module on if there is fogging or soiling on its optical parts!
- Do not touch any of the module's optical parts with bare hands!
- Proceed with care when removing dust or contamination from optical surfaces!
- Prevent shock impacts during and use of the LDM 41/42 E!
- Prevent overheating of the LDM 41/42 E!
- Prevent major temperature variances during LDM 41/42 E operation.
- In accordance with IP65 internal protection standards, the LDM 41/42 E is designed to be splash proof and dustproof.
- Read these safety and operating instructions with due care and follow them in practical use.

### 3. Technical Data

Measurement range <sup>4</sup> :	0.1 m up to 30 m with natural surfaces, depending on target reflectance or reflectors more than 100 m achievable <sup>5</sup>
Measuring accuracy <sup>6</sup> :	± 2 mm under defined measuring conditions <sup>7</sup> ± 3 mm (+15 °C up to +30 °C) ± 4 mm in DS mode <0.5 m (+15 °C ... 30 °C) ± 5 mm (-10 °C up to +50 °C)
Resolution <sup>8</sup> :	0.1 mm, user scalable, standard 1 mm
Reproducibility:	± 0.5 mm
Measuring time:	0.24 up to 6 s setup or auto mode DT 0.1 s (10 Hz) mode DW at white surface 20 ms (50 Hz) mode DX at white surface (only LDM 42 A)
Target motion speed:	≤ 4 m/s in DX-Mode (LDM 42 E only)
Acceleration:	≤ 2.5 m/s <sup>2</sup> in DX-Mode (LDM 42 E only)
Operating temperature:	- 10 °C up to + 50 °C - 40 °C up to + 50 °C (LDM 41/42 E /h only)
Storage temperature:	- 20 °C up to + 70 °C
Supply voltage:	10 V up to 30 V DC (protected against polarity reversal) <sup>9</sup>
Power consumption:	depending on operating mode < 0.4 W for standby, < 1.5 W for distance tracking, < 24 W with heating active (LDM 4x E /h only)

---

<sup>4</sup> dependent on target reflectance, stray light influences and atmospheric conditions

<sup>5</sup> e.g. 3M, self adhesive foil white non glossy

<sup>6</sup> statistic spread 95 %

<sup>7</sup> for measurement at a planar white target surface in continues movement or still standing, +15 up to +30 °C

<sup>8</sup> dependent on target reflectance, stray light influences and atmospheric conditions

<sup>9</sup> Please use only 24V DC For devices with heating (LDM 41/42 E / h) the heater is connected directly to the power supply.

Data interface:	Fast Ethernet 10/100 MBit and for start-up and service a RS 232, baud rate 38400 (2400...38400), ASCII, format 8N1 (fix)
Digital switching output:	"High-Side switch", programmable switching threshold and hysteresis, rated for max. load of 0.5 A, HIGH = UB - 2 V, LOW < 2 V
Trigger input <sup>10</sup> :	external trigger, trigger pulse 3 up to 24 V, pulse length ≥ 1 ms, start of measurement 5 ms + trigger delay, programmable trigger slope and delay can be set (0 ms ... 9999 ms),
EMC:	EN 61326-1
Shock resistance:	10 g / 6 ms persistence shock DIN ISO 9022-3-31-01-1
Laser Class:	Laser Class 2, under EN60825-1:2007, Class 2
Wave length:	650 nm (red visible)
Laser divergence <sup>11</sup> :	0.6 mrad
Laser angle tolerance:	better than ± 1° to the ground plane
Average service life:	100,000 h at 60 °C Laser temperature (internal)
Connector Power, I/O:	5-pol. M12 female socket, A coded
Connector Ethernet:	4-pol. M12 female socket, D coded
Connector RS232:	4-pol. M12 male socket, A coded
Dimensions (LxWxH):	218 x 96 x 50 (mm)
Mounting:	100 x 85 (mm), 4 x M6 holes
Weight:	approx. 800 g
Protection class:	IP 65 (spatter water and dust protection)

---

<sup>10</sup> trigger function is not available for devices with internal heating (LDM 41/42 E /h)

<sup>11</sup> at 10 m distance the beam diameter is 6 mm, at a distance of 50 m it is 3 cm and at a distance of 100 m it is 6 cm

#### 4. Mechanical Mounting Conditions

The casing consists of a rugged, corrosion-resistant extruded aluminum profile with front-side and rear-side covers also in corrosion-resistant design. Four mounting holes are provided in the base plate for mechanical attachment of the LDM 41/42 E.

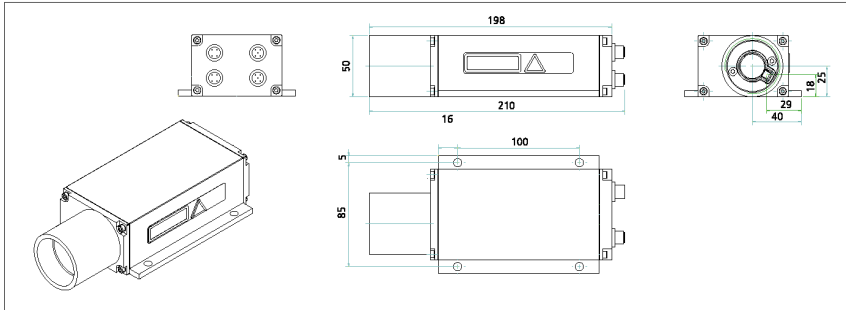
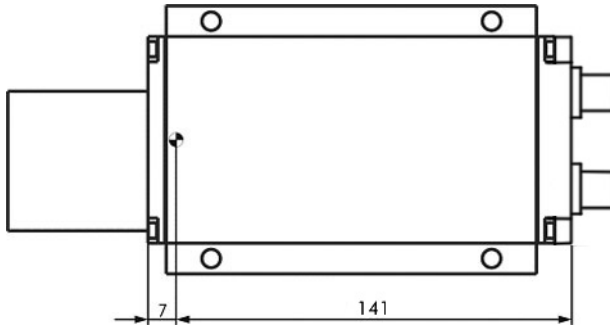

Figure 3: Dimensional drawing

To protect the sensor's optical surfaces from dust, physical contact, mechanical impacts, etc., the casing has a protection tube attached to it. Optionally different protection windows and optical filters are available. Please note that measurement cannot be guaranteed to function correctly if the equalizer tube is removed by unqualified action!

The interface connector is located on the back cover. Interface cables with different length are available (standard 2 m, optionally 5 or 10 m).



*Figure 4: Offset against zero-edge*

The LDM 41/42 E's zero-point is located 7 mm behind the outer surface of the front cover or 137 mm before the back cover outside face respectively. This zero-point has been introduced for constructional design reasons. It can be compensated with the help of parameter "OF" (see section 8.24 OF.....display/set distance offset).

## 5. Electrical Connection

### 5.1. Rear-Side Cover Terminals

Connector terminals are located on the rear-side cover of the device. The terminals consist of 4 buses for metal circular plug-in connectors (from Binder), or compatible connectors, sealed against the casing in compliance with IP 65 requirements. This connector type guarantees optimised screening and a high IP level.

The following connection plugs should be used:

Quantity	Connector Type	Use
1	4-pin male cable connector (series 715 D from Binder)	Fast Ethernet 10/100
1	5-pin male cable connector (series 713 A from Binder)	RS 232
1	5-pin female cable connector (series 713 A from Binder)	Power supply, switching output and trigger input



**Note:** Various connectors and cables are available. Please ensure that **only shielded connectors and shielded cables** are used.

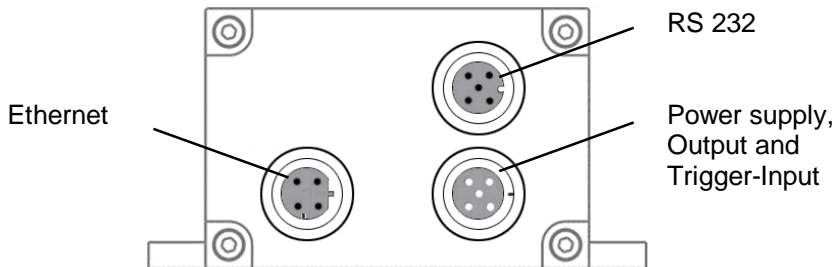

Figure 5 LDM 41/42 P terminals

## 5.2. Assignment of Terminals

### Power Supply

The required power supply is 10 to 30 V DC.

The trigger input allows for a distance measurement via an external signal in the form of a voltage impulse from 3 to 24 V (only DF mode, please see Chapter 8).

Pin	Description	Colour	Comment
1	VCC	brown	Power supply 10 to 30 V
2	OUT	white	Switching Output
3	GND	blue	Power supply 0 V
4	CONFIG	black	do not use (for service only)
5	TRIGGER	gray	Trigger input 3 to 24 V (ground potential GND)

### Fast Ethernet

The LDM 41/42 E has a terminal for circular plug-in connectors (series 715 D for Ethernet from Binder) conforming to the relevant standards.

Pin	Description	Comment
1	TD+	TD+, RJ45: 1 = white/orange
2	RD+	RD+, RJ45: 3 = white/green
3	TD-	TD-, RJ45: 2 = orange
4	RD-	RD-, RJ45: 6 = green



**Note:** Only use connection plugs and Ethernet cables that conform to the relevant standards.

## RS 232 Serial Interface



**Note:** All commands in Chapter 8 are possible with the RS 232 and also with Ethernet (Telnet)! The use of RS 232 can therefore usually be avoided!

The RS 232 interface was originally designed as a PC interface only. It has now become the standard for serial data transfer for short distances. It is subject to interference when used for longer distances, in particular, in environments with interfering high-frequency electromagnetic radiance. As a result, this interface should only be used for configuring the LDM 41/42 E. Please configure using the programming cable and the LDMTTool programme.



**Note:** The receiving line of the RS232 serial interface of the LDM 41/42 E is deactivated while connecting to the Telnet-client. If the Telnet connection is terminated, the full use of the RS 232 is again possible.

Please observe the RS 232 standard. The maximum extension of the RS 232 lines is 15 m.

Pin	Description	Colour	Comment
1	RxD	brown	Receiving line
2	TxD	white	Transmit line
3	GND	blue	Ground potential



**Note:** Following successful programming, remove the RS 232 cable and protect the RS 232 cable connector with the enclosed sealing plug against entry of dirt.

## Programming Cable

Connection to a PC requires the following cable with SUB-D 9 F connectors. The TxD and RxD signals of the LDM 41/42 E and the PC connection are crossed. The colours apply to the optional programming cable.

Pin LDM 4xE	Description	Colour	Pin SUB-D 9 F	Description
1	RxD	brown	3	TxD
2	TxD	white	2	RxD
3	GND	blue	5	GND

### **Shields and Grounding**

Cable shields must be grounded with low resistance. Only high quality shielded cables should be used.

Carrier bases and control boxes should have equal potential. Potential differences could lead to electrical currents and may cause EMC problems (no correct measurement function or switching the gauge off or on is necessary).

If no potential equalization is possible, then mount the LDM 41/42 P isolated from the carrier base (use nylon screws and washers). Connect the screen with mass to the cable end. This way of assembly should also be used when installing the LDM 41/42 P inside vehicles.

## 6. Limiting Values for Voltages

GND lines of the power supply and RS 232 terminals are connected internally and form the ground potential for all of the limiting values indicated below.

### Input voltages:

Terminal point	Voltage	Comment
VCC	+10 up to +30 V	pole-reversal-protected
CONFIG	do not input	only short to GND
TRIG	$\pm 25$ V	short-circuit-proof
RxD	$\pm 25$ V	short-circuit-proof

### Output voltages:

Terminal point	Voltage	Comment
OUT	like VCC ( $R_i$ 135 m $\Omega$ )	max. 0.7 A load; short-circuit-proof
TxD	$\pm 5.4$ V	short-circuit-proof

Limiting values of voltages, loads and logical levels comply with relevant RS 232 and Ethernet standards. All outputs are sustained-short-circuit-proof.

## 7. Start up

Make sure that all cable ends are protected against short circuit effects before you turn on power supply!

Connect cable terminals as required for the particular operating mode. To prevent short circuits, you should seal unused cable ends!

As part of preparative actions, the LDM 41/42 E must be properly installed in the designated working site, oriented onto the target and kept in a stable position. The target to be measured should preferentially have a homogeneous, bright surface.



**Caution: Do not use any retro reflectors!**

The alignment of the LDM 41/42 E is facilitated by a Laser beam<sup>12</sup> that is visible and can easily be turned on at the PC (e.g. command DT starting the measurement and switch the Laser on, see 8.2).

### 7.1. Start up with RS 232

For starting up, a PC with RS232 data interface or a USB converter for RS 232 and a terminal program are required. We recommend the Windows program LDMT00L Version 4.0 or higher.

---

<sup>12</sup> depending on ambient light and target conditions

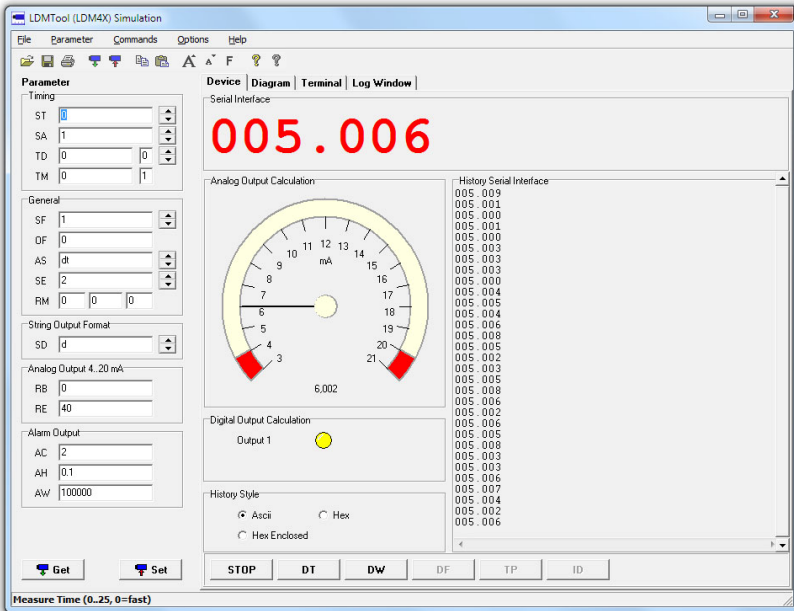

Figure 5: Program LDMTool

## 7.2. Start up with Ethernet

The LDM 41/42 E comes with a default IP address and subnet mask:

IP-Address: 192.168.0.51

Net mask: 255.255.0.0

Alternatively, there is a removable sticker with this information on the device.

Connect the LDM 41/42 E over a Switch or Hub to the network.

If the IP address of your PC does not start with 192.168 ... you have to unplug the PC from the network and change the IP of your PC and establish a local connection to the PC.

You can discover the IP address of your PC with Start | Run cmd (starting the command input) and the then command ipconfig.

Use the program "EtherTool" by ASTECH and run "Search". Alternatively, start a telnet client (Windows Telnet, putty or other via TCP/IP port 23) and connecting you with specifies the IP of the LDM 41/42 E.

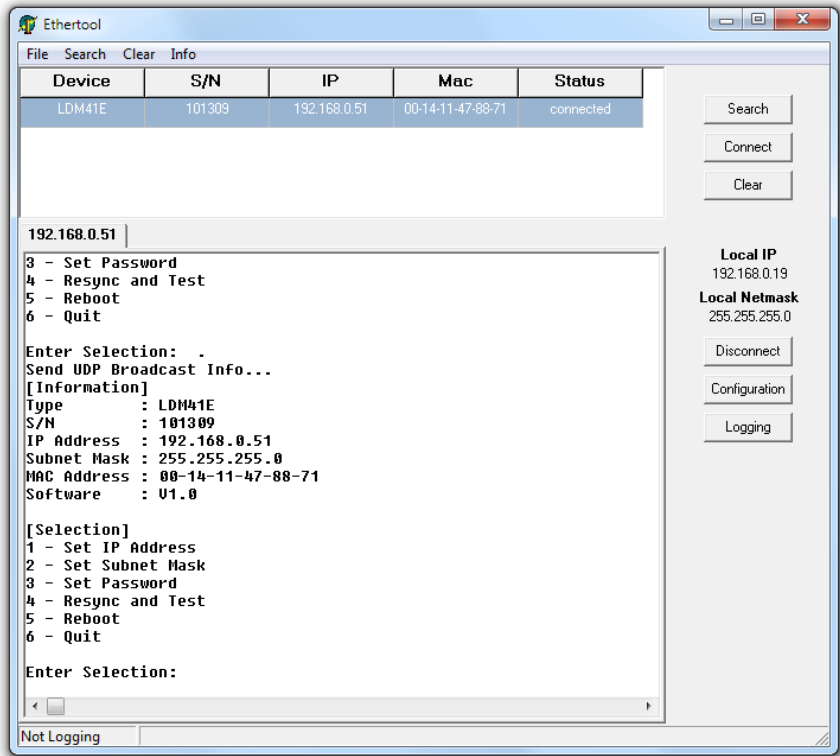
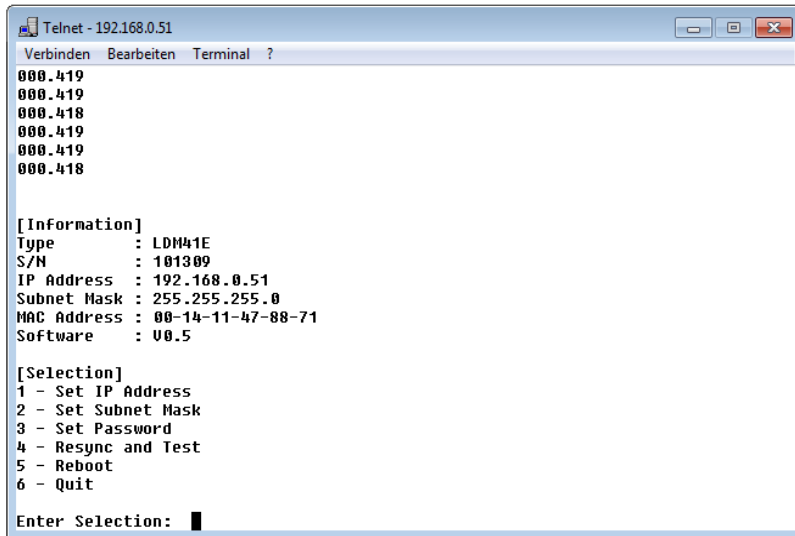

Figure 6: Program EtherTool



```
Telnet - 192.168.0.51
Verbinden  Bearbeiten  Terminal  ?

000.419
000.419
000.418
000.419
000.419
000.418

[Information]
Type       : LDM41E
S/N       : 101309
IP Address : 192.168.0.51
Subnet Mask : 255.255.255.0
MAC Address : 00-14-11-47-88-71
Software  : V0.5

[Selection]
1 - Set IP Address
2 - Set Subnet Mask
3 - Set Password
4 - Resync and Test
5 - Reboot
6 - Quit

Enter Selection: █
```

Figure 7: Program Telnet for Windows<sup>13</sup>

After Telnet connection is established, you get by entering the "#" in the configuration mode (see image above). By entering the number corresponding to [Selection], you can change IP addresses and subnet mask.



**Attention:** The changed IP addresses and subnet mask is active after a restart of the device! Then you must re-establish the Telnet connection.

The configuration mode can be protected by a password. The password must be at least 4 characters long. If no password characters are entered it will be cleared.



**Attention:** Store the password secure and loss protected. The configuration mode can call no longer without the password!

You can use also the program LDMTTool via an Ethernet connection. Therefore you need software to generate a virtual serial port.

---

<sup>13</sup> The Windows 7 Telnet Client must be activated before using. Please activate the Telnet Client with Control Panel, Programs, Programs and Features, Turn Windows features on or off and check then the box Telnet Client.

## 8. Commands and Parameter

### 8.1. General

The LDM 41/42 E can be parameterized very easy with the PC. The PC must be equipped with a serial interface RS 232 and/or RS 422 according to the attached LDM 41/42 E. The use of USB to serially converters is also possible. An optionally programming cable is necessary. On the PC a terminal program must be installed (LDMTool or HyperTerminal). By selecting ID[Enter] command, you may call up the menu with available setup commands (DX[Enter] only LDM 42 E):

```
LDM4x, s/n xxxxxx, V 7.x
DT[Enter].....distancetracking
DS[Enter].....distancetracking 7m
DW[Enter].....distancetracking with cooperative target(10Hz)
DX[Enter].....distancetracking with cooperative target(50Hz)
DF[Enter].....distance measurement with external trigger
DM[Enter].....distance measurement
TP[Enter].....internal temperature [C]
SA[Enter] / SAX[Enter].....display/set average value [1..20]
SD[Enter] / SDd[Enter].....display/set display format [d/h/s]
ST[Enter] / STx[Enter].....display/set measure time [0..25]
SF[Enter] / SFx.x[Enter].....display/set scale factor
SE[Enter] / SEx[Enter].....display/set error mode [0/1/2]
                                0..Iout=const., ALARM=const.
                                1..Iout: 3mA @RE>RB, 21mA @RE<RB,
                                ALARM: OFF@AH>0, ON@AH<0
                                2..Iout: 21mA @RE>RB, 3mA @RE<RB,
                                ALARM: ON@AH>0, OFF@AH<0
AC[Enter] / ACx.x[Enter].....display/set ALARM center
AH[Enter] / AHx.x[Enter].....display/set ALARM hysteresis
AW[Enter] / AWx.x[Enter].....display/set ALARM width
RB[Enter] / RBx.x[Enter].....display/set distance of Iout=4mA
RE[Enter] / REx.x[Enter].....display/set distance of Iout=20mA
RM[Enter] / RMx y.y z[Enter]..remove measurement
TD[Enter] / TDx y[Enter].....display/set trigger delay [0..9999ms]
                                trigger level [0/1]
TM[Enter] / TMx y[Enter].....display/set trigger mode [0/1] trigger
                                level [0/1]
BR[Enter] / BRx[Enter].....display/set baud rate [2400..38400]
AS[Enter] / ASd[Enter].....display/set autostart command [DT/DS/
                                DW/DX/DF/DM/TP/LO/ID]
OF[Enter] / OFx.x[Enter].....display/set distance offset
SO[Enter].....set current distance to offset
                                (offset = - distance)
LO[Enter].....Laser on
LF[Enter].....Laser off
PA[Enter].....display settings
PR[Enter].....reset settings
```

Figure 8: Help text Firmware V7.x, devices without heading

## Commands and Parameter

---

```
LDM42, SN xxxxx, V 8.02
DT[Enter].....distance tracking
DS[Enter].....distance tracking 7m
DW[Enter].....distance tracking with cooperative target
                (10Hz)
DX[Enter].....distance tracking with cooperative target
                (50Hz)
DM[Enter].....distance measurement
TP[Enter].....internal temperature [C]
SA[Enter] / SAX[Enter].....display/set average value [1..20]
SD[Enter] / SDD[Enter].....display/set display format [d/h/s]
ST[Enter] / STx[Enter].....display/set measure time [0..25]
SF[Enter] / SFx.x[Enter].....display/set scale factor
SE[Enter] / SEx[Enter].....display/set error mode [0/1/2]
                0..Iout=const., ALARM=const.
                1..Iout: 3mA @RE>RB, 21mA @RE<RB, ALARM:
                OFF@AH>0, ON@AH<0
                2..Iout: 21mA @RE>RB, 3mA @RE<RB, ALARM:
                ON@AH>0, OFF@AH<0
AC[Enter] / ACx.x[Enter].....display/set ALARM center
AH[Enter] / AHx.x[Enter].....display/set ALARM hysteresys
AW[Enter] / AWx.x[Enter].....display/set ALARM width
HO[Enter] / HOx[Enter].....display/set temperature of heating on [ -40*C
                ... +70*C]
HF[Enter] / HFx[Enter].....display/set temperature of heating off[ -40*C
                ... +70*C]
RB[Enter] / RBx.x[Enter].....display/set distance of Iout=4mA
RE[Enter] / REx.x[Enter].....display/set distance of Iout=20mA
RM[Enter] / RMx y y z[Enter]..remove measurement
BR[Enter] / BRx[Enter].....display/set baud rate [2400..38400]
AS[Enter] / ASd[Enter].....display/set autostart command
                [DT/DS/DW/DX/DM/TP/LO/ID]
OF[Enter] / OFx.x[Enter].....display/set distance offset
SO[Enter].....set current distance to offset
                (offset = -distance)
LO[Enter].....laser on
LF[Enter].....laser off
PA[Enter].....display settings
PR[Enter].....reset settings
```

Figure 9: Help text Firmware V8.x, devices with heading

In preparation of a measurement so the sensor can be adapted by intelligent parameterize optimally to the measuring conditions and the measuring task.

All valid settings will be preserved on turning the LDM 41/42 E off! They can only be replaced with new value entries or changed back to their standard values by running an initialization routine.

Command entries are not case-sensitive. This means that small and capital lettering can be used for commands.

Any command must be terminated by a hexadecimal 0Dh (carriage return) character.

Where decimal digits are to be entered, they must be separated by period (2Eh).

For command parameter entries, one must distinguish between parameter settings and parameter queries.

Querying is achieved with a command in simple format, e.g. (for alarm center parameters):

AC[Enter]

For parameter setting, a new value must be added after the command with no delimitation sign in between, for example:

AC20.8[Enter]

In the given example, the alarm center will be set to 20.8.

The following is a short overview of the commands:

Command	Description
<b>DT</b>	Starts distance tracking
<b>DS</b>	Starts distance tracking (< 7 m)
<b>DW</b>	Starts distance tracking on white target at 10 Hz
<b>DX</b>	Starts distance tracking on white target at 50 Hz (only LDM 42 E)
<b>DF<sup>14</sup></b>	Starts remote-triggered single distance measurement
<b>DM</b>	Starts single distance measurement
<b>TP</b>	Queries inner temperature
<b>SA</b>	Queries / sets floating average value (1...20)
<b>SD</b>	Queries / sets output format ( <b>dec/hex/sig</b> )
<b>ST</b>	Queries / sets time to measure (0...25)
<b>SF</b>	Queries / sets scale factor
<b>SE</b>	Queries / sets error mode (0, 1, 2)

---

<sup>14</sup> Trigger function is not available for devices with internal heating (LDM 41/42 E /h)

## Commands and Parameter

---

<b>AC</b>	Queries / sets alarm center
<b>AH</b>	Queries / sets alarm hysteresis
<b>AW</b>	Queries / sets alarm with
<b>HO</b> <sup>15</sup>	Queries / sets temperature for heating on
<b>HF</b> <sup>15</sup>	Queries / sets temperature for heating off
<b>RB</b>	No function
<b>RE</b>	No function
<b>RM</b>	Queries / sets removal measurement parameters
<b>TD</b>	Queries / sets trigger delay and level
<b>TM</b>	Queries / sets trigger mode and level
<b>BR</b>	Queries / sets baud rate
<b>AS</b>	Queries / sets auto start
<b>OF</b>	Queries / sets offset
<b>SO</b>	Sets current distance as offset
<b>LO</b>	Turns Laser on
<b>LF</b>	Turns Laser off
<b>PA</b>	Displays all parameter values
<b>PR</b>	Resets all parameters to standard values (don't use)

---

<sup>15</sup> Only for devices with internal heating (LDM 41/42 E /h)

## 8.2. DT.....distance tracking

Input parameter SA, SD, SE, SF, ST, OF

Output RS232/RS422, digital switching output

DT mode can be chosen for distance measurement of different kinds of surfaces (varying reflectance). In this type of distance tracking mode, the LDM 41/42 E uses internal algorithms to continuously evaluate the quality of the Laser radiation signal that is coming back. This may cause longer measuring times in the case of poor reflectance or sudden jumps in distance.

The minimum time to measure is 240 ms, the maximum time is 6 s. If the measuring signal fails to reach a specified quality within six seconds, an error message is output.

The time to measure may also be limited by setting the ST parameter to a desired value. ESC stops the measurement.

## 8.3. DS.....distance tracking (< 7 m)

Input parameter SA, SD, SE, SF, ST, OF

Output RS232/RS422, digital switching output

Operation in DS mode makes sense where different types of surfaces have to be measured at close range up to 7 m. Compared to DT measuring mode, it allows a higher measurement rate. Within the range from 0.1 m to 0.5 m, measuring accuracy is restricted ( $\pm 4$  mm).

Measuring time (time to measure) can be limited via ST parameter settings.

ESC stops the measurement.

## 8.4. DW.....distance tracking with target board (10Hz)

Input parameter SA, SD, SE, SF, OF

Output RS232/RS422, digital switching output

DW mode performs at a steady measuring rate of 10 Hz. As a necessary precondition for measured values to be stable, a white target board must be placed at the selected object. There must be no sudden jumps in distance greater than 16 cm within the measuring field!

ESC stops the measurement.

### 8.5. DX.....distance tracking with target board (50Hz)

Input parameter SA, SD, SE, SF, OF  
Output RS232/RS422, digital switching output

DX mode performs at a steady measuring rate of 50 Hz (only LDM42). As a necessary precondition for measured values to be stable, a white target board must be placed at the selected object.

This measurement mode is intended in the first place for objects performing homogeneous motion up to 4m/s. For higher rates of measurement, preceding measured values will be included in the process to calculate a currently measured value. There must be no sudden jumps in distance greater than 16 cm within the measuring field!



**Caution: To prevent transmission problems, please use 38400 baud for DX Mode (Standard baud rate).**

### 8.6. DF.....distance measurement with external trigger<sup>16</sup>

Input parameter SD, SE, SF, ST, OF, TD, ST, SA, RM  
Output RS232/RS422, digital switching output

DF mode allows a measurement that is triggered by an external trigger pulse.

Initially, after selecting this mode, the operator does not receive any response. As soon as the trigger pulse has been detected, the LDM 41/42 E will send data and switches to digital output.

Settings for trigger delay (delay) and trigger slope can be defined via parameter TD (see 8.20 TDx y.....display/set trigger delay and trigger level).

With ST=1 the maximum trigger frequency should not exceed 3.5 Hz.

---

<sup>16</sup> Trigger function is not available for devices with internal heating (LDM 41/42 E /h)

**8.7. DM.....distance measurement**

Input parameter SD, SE, SF, ST, OF

Output RS232/RS422, digital switching output

DM mode triggers a single measurement (single shot).

**8.8. TP.....internal temperature [°C]**

TP queries the value of the inner LDM 41/42 E temperature.

Note: In tracking mode, the inner temperature may exceed the surrounding temperature level by as much as 10 K.

**8.9. SA.....display/set average value [1..20]**

SA allows you to calculate a floating average value from 1 to 20 measured values. Calculation is based on this formula:

$$\text{Average value } x = \frac{X_1 + X_2 + X_3 + \dots + X_n \text{ (20)}}{n}$$

Standard setting is 1 (no average).

### 8.10. SD.....display/set display format [d/h/s]

SD selects the output format of measured value data. There are three modes available:

Parameter	Output	Format
d	decimal	xxx.xxx<CR><LF> x=0...9
h	hexadecimal	<SPACE>xxxxxx<CR><LF> x=0...F
s	decimal with signal quality	xxx.xxx<SPACE>yyyyyy<CR><LF> x=0...9; y=0...9

SD affects all commands that output a distance value.

An output value is calculated from a given measured distance value (in mm), multiplied by the scale factor SF.

Negative distance values are output in two's complement notation.

The value for the signal quality varies between 0 and 1024. 0 means a bad signal quality while 1024 indicates a very good signal quality.

Examples:

Distance = 4.996 m, SF1

```
dec:      004.996<CR><LF>
hex:      _001384<CR><LF> (= 4996 mm x SF1)
dec+sig:  004.996_000005<CR><LF> (bad signal quality)
dec+sig:  004.996_000985<CR><LF> (good signal quality)
```

Distance = 4.996 m, SF10

```
dec:      049.960<CR><LF>
hex:      _00C328<CR><LF> (= 49960 = 4996 mm x SF10)
dec+sig:  004.996_000005<CR><LF> (bad signal quality)
dec+sig:  049.960_000985<CR><LF> (good signal quality)
```

Error case

```
dec/hex:  E15<CR><LF>
(see page 49 chapter 11 Error Codes)
```

### 8.11. ST.....display/set measure time [0..25]

Measuring time is directly conditional on the selected measuring mode. As a general rule, one may say: the poorer the reflectance of the surface of a particular target, the more time the LDM 41/42 E will require to determine the distance with specified accuracy. For example, if error message E15 is output because of poor reflectance and insufficient time to measure, this latter setting must be increased.

The available value range for measuring time is 0 to 25. Basically, the greater the time setting is the more time will be available for measurement and the lower the resulting measuring rate.

An exception there from is zero-value. In this case, the LDM 41/42 E automatically picks the smallest possible time value for measurement! The LDM 41/42 E comes factory-set with  $ST = 0$ .

ST is effective in the DT, DF and DM mode of operation.

The measuring time setting option can also be used to modify the measuring rate, for example, in order to restrict the data volume or for synchronization purposes. Measuring time can only be set as an approximate value, because the underlying principle of measurement is subject to certain variances that cannot be accounted for:

DT measuring mode → measuring time =  $ST \times 240$  ms (except  $ST = 0$ )

DS measuring mode → measuring time =  $ST \times 150$  ms (except  $ST = 0$ )

Example:

The target distance is 25 m, but the target's reflectance is not ideal. With a measuring time setting of ST 2, E15 will be output following measurement. The user must increase the time ( $ST > 2$ ) or set auto ( $ST 0$ ) to measure in this case!



**One should work in DW or DX measuring mode where stable measuring times are required.**

### 8.12. SF.....display/set scale factor

SF multiplies a calculated distance value with a user-selectable factor for changes in resolution or outputs in a different unit of measure. The scale factor may also be negative. Standard setting is 1.

The scale factor influence the output of measurement results, Offset (OF), Alarm Centre (AC) and Alarm Hysteresis (AH)!

Scale factor	Resolution	Output	Output Unit
SF1	1 mm	12,345	m
SF10	0,1 mm	123,45	dm
SF1.0936	0,01 yard	13.500	yard
SF3.28084	0,01 feet	40.501	feet
SF0.3937	1 inch	4.860	100 inch
SF-1	1 mm	-12.345	m



**Note: Following a change in the scale factor, the settings for digital output and offset must be matched accordingly!**

**8.13. SE.....display/set error mode [0/1/2]**

SE (error mode) allows you to configure the behaviour of the digital switching output (alarm) following an error message (E15, E16, E17). Depending on the particular LDM 41/42 E application environment, error messages have to be handled in different ways. Available setting options are 0, 1 and 2 with the following effects in the case of an error:

SE	Digital switching output (Alarm)
0	ALARM of latest valid measurement
1	Positive alarm hysteresis = LOW Negative alarm hysteresis = HIGH
2	Positive alarm hysteresis = HIGH Negative alarm hysteresis = LOW

**8.14. AC.....display/set ALARM center**

AC sets the beginning of the distance range, for which the switching output will be turned active. The length of this active range can be set using the AW parameter. AC must be selected in keeping with the currently set SF scale factor (see 9.4 Digital Switching Output (Alarm)).

**8.15. AH.....display/set ALARM hysteresis**

AH allows you to make parameter settings for the switching hysteresis at the beginning and the end point of the active range of the switching output. AH must be selected so it is properly matched to the currently valid scale factor (SF). The mathematical sign of AH can be used to set an active state logic level:

- Positive sign (“+”): active range is HIGH-active.
- Negative sign (“-”): active range is LOW-active.

No sign setting means positively-signed (see 9.4 Digital Switching Output (Alarm)).

### **8.16. AW.....display/set ALARM width**

AW sets the length of the active range, beginning at AC.  
AW settings must be made in agreement with the currently valid SF scale factor.

AW is always equal or greater than "0" (zero).

AW is always equal or greater than |AH| (the amount of AH).

Standard setting is 100000 – means off.

### **8.17. HO.....display/set temperature for heating on<sup>17</sup>**

HO displays/sets the temperature value at which the internal heating is switched on. The values can be varied between -40°C and 70°C.

Standard setting is 3°C.

### **8.18. HF.....display/set temperature for heating off<sup>17</sup>**

HF displays/sets the temperature value at which the internal heating is switched off. The values can be varied between -40°C and 70°C.

Standard setting is 12°C.

---

<sup>17</sup> Only for devices with internal heating (LDM 41/42 E /h)

### 8.19. RMx y z.....display/set remove measurement

Standard setting: 0 0 0

RM is intended to facilitate settings for a range of expected distance values.

Values which are found to be outside of this expected range will be corrected until matching the most recently valid measured values.

RM is only effective in DT mode.

It consists of three parameters which are separated by space (20h).

- x designates the number of preceding measured values that will be evaluated in the case of non-conforming measurement. A maximum of ten preceding measured values can be evaluated.
- y defines the range of permissible values. If this range is exceeded in negative or positive direction, the respective measured value will be corrected accordingly.
- z stands for the number of values that are out of the permissible value range (out of tolerance values). In the event of out-of-tolerance values arriving in succession, the most recently corrected value will be included in the correction process for the next out-of-tolerance value. The maximum allowed number of out-of-tolerance values is 100.



**Important: The use of RM parameter settings should be restricted to suitable applications only. Improper use of this parameter may create safety hazards!**

### 8.20. TDx y.....display/set trigger delay and trigger level<sup>18</sup>

TD is only intended for the configuration of the remote trigger input (see 8.6 DF.....distance measurement with external trigger).

TD consists of two sub parameters, of the actual delay value, i.e. the delay time, and the trigger level.

Trigger delay corresponds to the time from arrival of the trigger signal to the starting point of a measurement. It may be set to any value between 0 and 9999 ms. With the help of the trigger level one may define if measurement is to begin on a rising or a falling pulse slope.

Trigger delay and trigger level must be separated by space (20h) in the entry line. Standard setting: 0 0.

- x Delay time between trigger signal and start of measurement ,  
delay can be set from 0 to 9999 ms.
- y 0 for HIGH → LOW-slope  
1 for LOW → HIGH-slope

Example:

```
TD1000_0[Enter]
```

In the given example, the delay has been set to 1000 ms and the trigger slope to “rising” (LOW-to-HIGH transition).

---

<sup>18</sup> Trigger function is not available for devices with internal heating (LDM 41/42 E /h)

### 8.21. TMx y.....display/set trigger mode trigger level<sup>19</sup>

TM provides parameter setting options for the auto-start trigger function which allows external triggering of the auto-start command that was set via parameter AS. Triggering is accomplished via the external trigger input. All starting modes which are selectable via AS can be launched and stopped by external triggering. These are:  
DS/DT/DW/DX/DF/DM/TP/LO/ID.

TM consists of two parameters which are separated by space (20h).

- x    0...trigger function turned off  
      1...trigger function turned on
  
- y    0...measurement is triggered on trigger line at L-level  
      (HIGH → LOW slope)  
      1...measurement is triggered on trigger line at H-level  
      (LOW → HIGH slope)

Standard setting is TM0 1.

For triggering, the trigger level must be permanently applied!

---

<sup>19</sup> Trigger function is not available for devices with internal heating (LDM 41/42 E /h)

Examples:

- a) ASDT  
TM1 1  
Trigger signal = H → DT is performed  
Trigger signal = L → DT is stopped

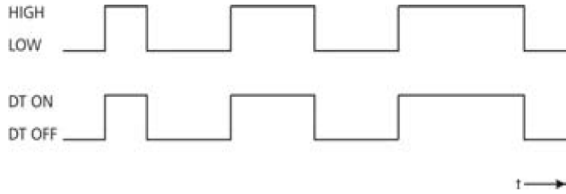

Figure 10: Trigger level = 1

- b) ASDM  
TM1 0  
Trigger signal=H → no change in state  
Trigger signal=L → DM active, i.e. one measurement is Triggered

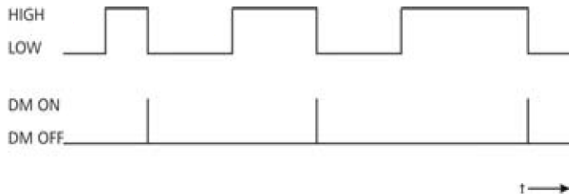

Figure 11: Trigger level = 0

### **8.22. BR.....display/set baud rate [2400..38400]**

Available baud rate settings are: 2400, 4800, 9600, 19200, 38400.

Faulty entries will be rounded to the nearest baud rate.

A fixed data format of eight data bits, with no parity and one stop bit is used. Standard setting is 9600 baud.

### **8.23. AS....display/set auto start command**

AS (auto start) defines which function will be carried out when power becomes available to the LDM 41/42 E.

Possible entries are those delivering a measured value on the output side, an ID command or the command for turning the Laser on (LO).

For example, if ASDT has been parameterized, the LDM 41/42 E will begin with distance tracking on turning on power.

### **8.24. OF.....display/set distance offset**

With the help of OF (offset) the user may define a zero-point for his/her application. For details on the position of the module's zero-point, refer to section 4.

OF must be selected so it is properly matched to the currently valid scale factor setting (SF).

OF may also take on negative values. Standard setting: 0

### **8.25. SO.....set current distance to offset**

SO performs a distance measurement and saves the measured reading as an offset value with inverted mathematical sign (OF).

### **8.26. LO.....Laser on**

LO turns the Laser on. This function can be used for orientation or functional testing of the LDM 41/42 E. After the command LO it's necessary to send LF! Don't use LO because this. Please use instead of LO the command DT to turn the Laser on.

### **8.27. LF.....Laser off**

LF turns the Laser off.

### 8.28. PA.....display settings

PA lists all parameters in a table.

### 8.29. PR.....reset settings

PR resets all parameters (except for baud rate). After this a new configuration of the LDM 41/42 E is necessary!

```
average value[SA].....1
display format[SD].....d
measure time[ST].....0
scale factor[SF].....1
error mode[SE].....1
ALARM center[AC].....1000
ALARM hysteresis[AH].....0.1
ALARM width[AW].....100000
remove measurement [RM].....0 0 0
trigger delay, trigger level[TD]..0 0
trigger mode, trigger level[TM]...0 1
baud rate[BR].....9600
autostart command[AS].....ID
distance offset[OF].....0
```



**Use instead of PR the “Set Standard” command from Windows program LDMTTool.**

## 9. In- and Outputs

### 9.1. Ethernet

Ethernet is the most widely used standard for wired networks. The LDM 41/42 E realized Fast Ethernet with 100 MBit / s.

The data is transmitted using Telnet (port 23). This must be established with a Telnet client connects to the Telnet server in the LDM 41/42 E.

The program EtherTool provides an integrated telnet client.

The commands are described in chapter 8 starting page 23. The data output format is determined by parameter SD (display format), see page 30.

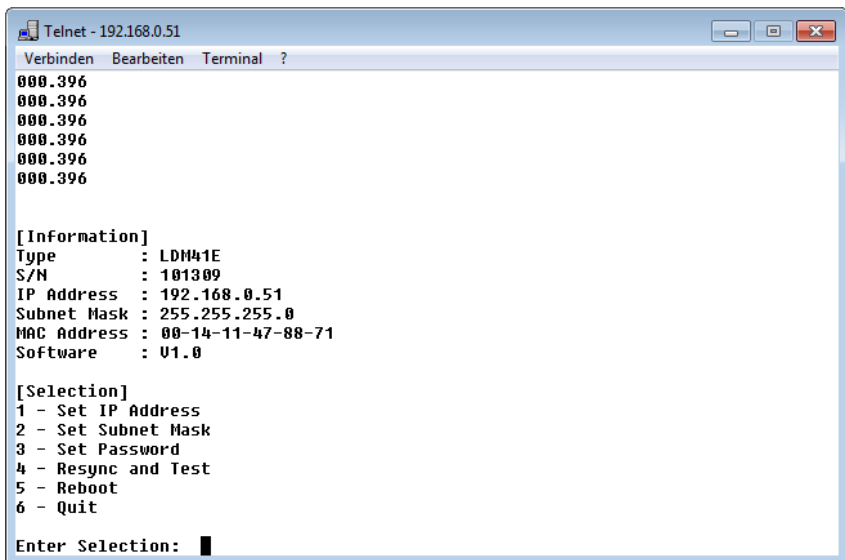

```
Telnet - 192.168.0.51
Verbinden  Bearbeiten  Terminal  ?
000.396
000.396
000.396
000.396
000.396
000.396

[Information]
Type       : LDM41E
S/N        : 101309
IP Address : 192.168.0.51
Subnet Mask : 255.255.255.0
MAC Address : 00-14-11-47-88-71
Software   : U1.0

[Selection]
1 - Set IP Address
2 - Set Subnet Mask
3 - Set Password
4 - Resync and Test
5 - Reboot
6 - Quit

Enter Selection: █
```

Figure 12: Telnet Program

The device can also be accessed via a browser (Firefox, Internet Explorer<sup>20</sup> etc.) via http (port 80). Only one browser can access to the HTML page at the same time. Inputs are not available!

<sup>20</sup> With the Internet Explorer select at first under "Tools | Security | Internet Options" the option "Local Intranet" and then click on "Sites". In the new window must be clicked on "Advanced" and in the next window add the IP address of the LDM, for example: "http://192.168.0.51".

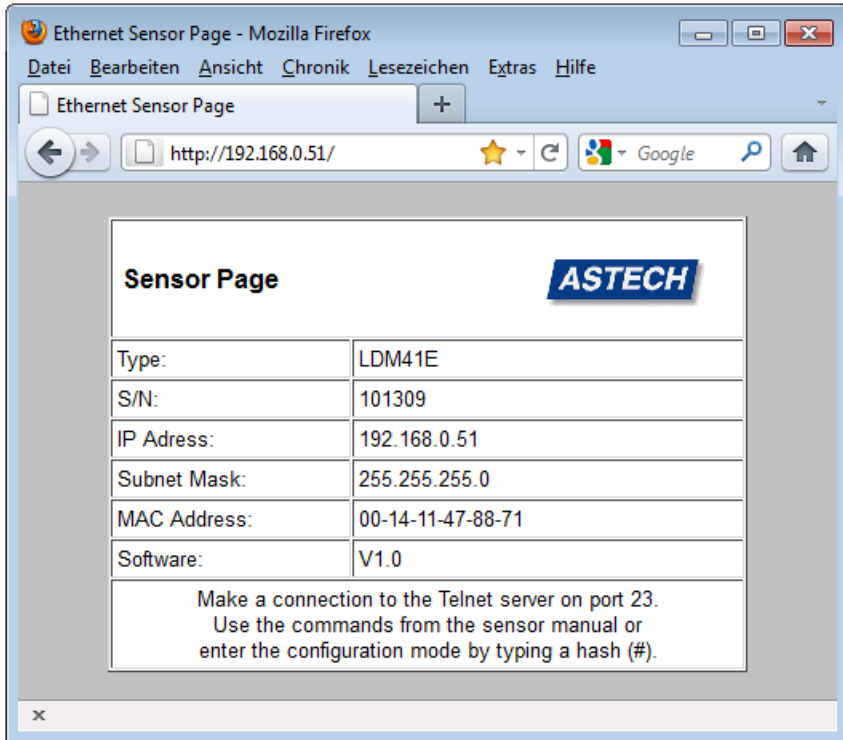

Figure 13: LDM 41/42 E Sensor Page

## 9.2. Serial Interface RS232

Initially, RS232 communication interfaces purely functioned as PC communication ports. They have become the established standard tool for serial data transmission over short cable lengths. With greater transmission lengths, the interface is highly susceptible to interferences, notably, in the vicinity of strong electromagnetic noise emitters. Therefore, it should only be used for LDM 41/42 E configuration. The commands of the serial interface are described in chapter 8 starting page 23. The data output format is determined by parameter SD (display format), see page 30.

### 9.3. Output Format Ethernet and RS232

The output format for data output is selected by the command SD. There are three modes available:

Parameter	Output	Format
d	decimal	xxx.xxx<CR><LF> x=0...9
h	hexadecimal	<SPACE>xxxxxx<CR><LF> x=0...F
s	decimal with signal quality	xxx.xxx<SPACE>yyyyyy<CR><LF> x=0...9; y=0...9

SD affects all commands that output a distance value.

An output value is calculated from a given measured distance value (in mm), multiplied by the scale factor SF.

Negative distance values are output in two's complement notation.

The value for the signal quality varies between 0 and 1024. 0 means a bad signal quality while 1024 indicates a very good signal quality.

Examples:

Distance = 4.996 m, SF1

```
dec:      004.996<CR><LF>
hex:      _001384<CR><LF> (= 4996 mm x SF1)
dec+sig:  004.996_000005<CR><LF> (bad signal quality)
dec+sig:  004.996_000985<CR><LF> (good signal quality)
```

Distance = 4.996 m, SF10

```
dec:      049.960<CR><LF>
hex:      _00C328<CR><LF> (= 49960 = 4996 mm x SF10)
dec+sig:  004.996_000005<CR><LF> (bad signal quality)
dec+sig:  049.960_000985<CR><LF> (good signal quality)
```

Error case

```
dec/hex:  E15<CR><LF>
(see page 49 chapter 11 Error Codes)
```

### 9.4. Digital Switching Output (Alarm)

With the help of a user-selectable distance threshold, the switching output can be set to monitor objects or conditions for positive or negative overstep.

The digital output is realized by means of High-Side switch. He switched to VCC - a load is needed to GND. Formerly a switching to positive output was called PNP output.

For example, using the digital switching output, an object which was selected for measurement can be monitored for excision of a threshold value. To do this, parameter settings for a measurement window are required. Settings for this window can be made via the three parameters: Alarm Center (AC), Alarm Hysteresis (AH) and Alarm Width. The range which will be subject to monitoring begins at AC and ends at AC+AW. Switching transitions can be set via parameter AH. The logic state of the switching output follows from the mathematical sign of AH.

In the case of a positive AH, the output switches

- with increasing distance:
  - from LOW to HIGH if the distance is greater than  $(AC \pm AH/2)$
  - from HIGH to LOW if the distance is greater than  $(AC+AW+AH/2)$
- with decreasing distance:
  - from LOW to HIGH if the distance is smaller than  $(AC +AW-AH/2)$
  - from LOW to HIGH the distance is smaller than  $(AC-AH/2)$

In the case of a negative AH, the output switching pattern will be inverse.

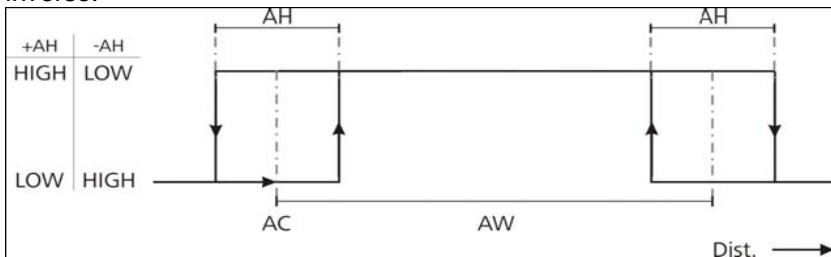

Figure 14: Digital switching output behavior with positive and negative hysteresis

Example:

A moving object is assumed to be monitored within a window of 10 m to 11 m with a hysteresis of 0.2 m.

AC10  
AH0.2  
AW1

Distance (m) increases →										
	9.8	9.9	10.0	10.1	10.2	...	11.0	11.1	11.2	11.3
+AH	L	L	L	H	H	H	H	L	L	L
-AH	H	H	H	L	L	L	L	H	H	H

Distance (m) decreases →										
	11,3	11,2	11,1	11,0	10,9	10,8	...	10,0	9,9	9,8
+AH	L	L	L	L	H	H	H	H	H	L
-AH	H	H	H	H	L	L	L	L	L	H

*L = LOW, H = HIGH*

How the switching output is to behave on occurrence of an error message (E15, E16, E17, E18) can be defined by making suitable settings under "SE" (see 8.13 SE.....display/set error mode [0/1/2]).

### 9.5. Trigger Input<sup>21</sup>

The trigger input is intended for triggering a distance measurement with an external signal that is applied as a voltage pulse between 3 V and 24 V. This input is used only in trigger mode DF (DF.....distance measurement with external trigger)!

It is for the user to specify a desired delay time and a pulse slope to be selected for synchronization (see 8.20 TDx y.....display/set trigger delay and trigger level). Having done this, the LDM 41/42 E has to be switched to trigger mode (see 8.6 DF.....distance measurement with external trigger).

---

<sup>21</sup> Trigger function is not available for devices with internal heating (LDM 41/42 E /h)

## 10. List of Commands

Command	Description
<b>DT</b>	Starts distance tracking
<b>DS</b>	Starts distance tracking (< 7 m)
<b>DW</b>	Starts distance tracking on white target at 10 Hz
<b>DX</b>	Starts distance tracking on white target at 50 Hz (only LDM 42 E)
<b>DF<sup>22</sup></b>	Starts remote-triggered single distance measurement (single shot)
<b>DM</b>	Starts single distance measurement (single shot)
<b>TP</b>	Queries inner temperature
<b>SA</b>	Queries / sets floating average value (1...20)
<b>SD</b>	Queries / sets output format ( <b>dec/hex/sig</b> )
<b>ST</b>	Queries / sets time to measure (0...25)
<b>SF</b>	Queries / sets scale factor
<b>SE</b>	Queries / sets error mode (0, 1, 2)
<b>AC</b>	Queries / sets alarm center
<b>AH</b>	Queries / sets alarm hysteresis
<b>AW</b>	Queries / sets alarm with
<b>HO<sup>23</sup></b>	Queries / sets temperature for heating on
<b>HF<sup>23</sup></b>	Queries / sets temperature for heating off
<b>RB</b>	No function
<b>RE</b>	No function
<b>RM</b>	Queries / sets removal measurement parameters
<b>TD</b>	Queries / sets trigger delay and level
<b>TM</b>	Queries / sets trigger mode and level

<sup>22</sup> Trigger function is not available for devices with internal heating (LDM 41/42 E /h)

<sup>23</sup> Only for devices with internal heating (LDM 41/42 E /h)

## List of Commands

---

<b>BR</b>	Queries / sets baud rate
<b>AS</b>	Queries / sets auto start
<b>OF</b>	Queries / sets offset
<b>SO</b>	Sets current distance as offset
<b>LO</b>	Turns Laser on (do not use, please use DT)
<b>LF</b>	Turns Laser off
<b>PA</b>	Displays all parameter values
<b>PR</b>	Resets all parameters to standard values (don't use)

## 11. Error Codes

Code	Description	Action
<b>E15</b>	Reflexes are too weak, <b>or</b> distance from LDM (front edge) to target is less than 0.1 m	Use white target board <sup>24</sup> <b>or</b> increase distance to target
<b>E16</b>	Reflexes are too strong	Use white target board or filter
<b>E17</b>	Too much steady light (e.g. sun) or reflexes are too strong	Use aperture or filter or white target board
<b>E18</b>	DX mode ( <b>only LDM 42 E</b> ): reflexes too weak, <b>or</b> distance from LDM (front edge) to target is less than 0.1 m	Use white target board <b>or</b> increase distance to target
<b>E23</b>	Inner temperature below – 10°C	Heating necessary
<b>E24</b>	Inner temperature above + 60°C	Cooling necessary
<b>E31</b>	EEPROM checksum error	Necessary to repair
<b>E51</b>	Failed to set avalanche voltage	Necessary to repair
<b>E52</b>	Excessively high Laser current / Laser defect	Necessary to repair
<b>E53</b>	Division by 0	SF must be unequal of zero or necessary to repair
<b>E54</b>	Hardware error, PLL range	Necessary to repair
<b>E55</b>	Other hardware error	Necessary to repair
<b>E61</b>	Invalid command	Correct input
<b>E62</b>	Wrong parameter, wrong command	Check data transmission
<b>E63</b>	SIO overflow	Check data transmission
<b>E64</b>	SIO framing error	Check data transmission

<sup>24</sup> e.g. 3M, self adhesive foil matte white

## 12. EC Declaration of Conformity



In accordance with the

Directive of Electromagnetic Compatibility 2004/108/EG

The company ASTECH Angewandte Sensortechnik GmbH in  
Schonenfahrerstr. 5, 18057 Rostock / Germany herewith declare,  
represented by the signatory, that the following designated product

**Laser Distance Measurement Sensor**

**LDM 41 E / LDM 42 E**

agree with the following harmonized standard:

**IEC 61326-1**

**Electromagnetic interference and electromagnetic compatibility  
(EMC) \*including radio interference**

Rostock, May 10. 2011

ASTECH Angewandte Sensortechnik GmbH

A handwritten signature in blue ink, appearing to read 'Volker Ahrendt'. The signature is fluid and cursive, with a long horizontal stroke at the end.

Volker Ahrendt  
General Manager

### 13. Part Numbers

Part-No.	Name
10-2028-00	LDM41E
10-2029-00	LDM42E
10-2036-00	LDM41E/h with heating
10-2037-00	LDM42E/h with heating
15-0018-00	Male cable connector Ethernet M12, 4-pin D-coded
15-0040-00	Connection cable Ethernet M12 - RJ45, 3m
15-0040-01	Connection cable Ethernet M12 - RJ45, 5m
15-0040-02	Connection cable Ethernet M12 - RJ45, 10m
15-0011-00	Female cable connector Power and I/O, 5-pin A-coded
15-2002-00	Connection cable Power and I/O, LDM41/42E, 5m
15-2002-01	Connection cable Power and I/O, LDM41/42E, 10m
15-0019-00	PC-Programming cable RS232 5m
11-0001-00	USB-RS232 Interface converter, 0.2m
12-2006-00	Protection window Standard for LDM4x-Series
12-2006-01	Protection window Quartz glass for LDM4x-Series
12-2006-02	Protection window Sapphire glass for LDM4x-Series
12-2007-00	Gray filter 2-fach for LDM4x-Series
12-2007-01	Gray filter 4-fach for LDM4x-Series
12-2010-00	Reflection foil matte/white, A4
12-2011-00	Highly reflective foil silver, A4
12-2015-00	Protection tube for pressure air for LDM4x-Series
16-0000-00	ASTECH CD (LDM, VLM)
16-2004-01	Printed Manual LDM41/42E, A5, DE
16-2004-02	Printed Manual LDM41/42E, A5, EN
17-2000-00	License number for PC-Software LDMTOOL for LDM3x und LDM4x

Note: Several single sensors are also available as packages including sensor and power cable, manual and CD (sets). Additionally are other protection enclosures with and without a thermostat available.



